



**FRESH 'N REBEL**

**AIR DRUMS**

**WIRELESS SPEAKER**

**+ 2 DRUMSTICKS**

**+ 2 FOOT PEDALS**

**INSTRUCTIONS**

**1AAD100 v1 001**



Scan the QR code or visit [freshnrebel.com/support/1AAD100](https://freshnrebel.com/support/1AAD100)  
for more instructions and the manual in your own language

# WHAT ARE AIR DRUMS?

Drumming anywhere, anytime - just you, your sticks, and the beat?

Create your own beats or play the most iconic basic drumming patterns, all of that with just your hands. The electronic Air Drums are designed for those who have less space, want to practice silently, and do so anywhere. Whether you play inside, outside, or perform on stage. Suitable for any age or level.

# HOW DOES DRUMMING WORK? + BASIC SETUP

**IMPORTANT:** The power button on the drumsticks should always be facing up while playing.

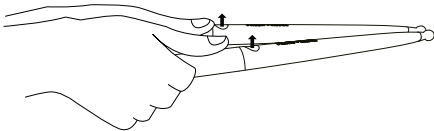

## 1. HAND-CONTROLLED DRUMS – STICK PLANES

Your drumsticks respond to movement in two planes. Keep an eye on the LED indicator on your sticks:

- Green, yellow, blue, cyan, magenta, orange light = in range – you can strike.
- Red light = out of range – adjust position before striking.

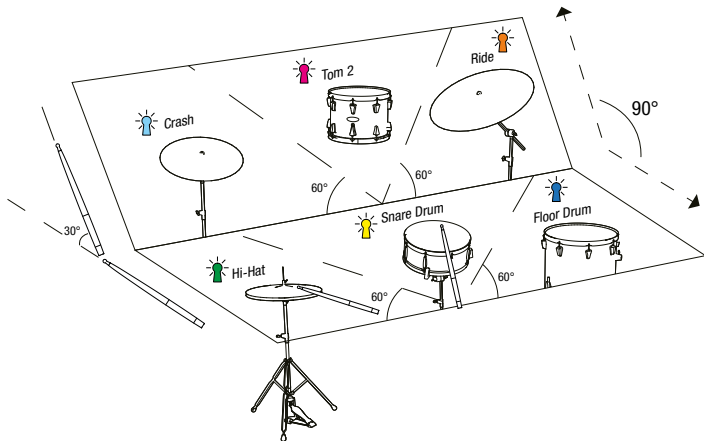

 Out of range

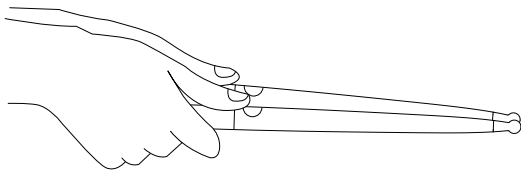

## FIRST PLANE – HORIZONTAL PLANE

Hold your drumsticks parallel to the ground, with the indicators facing forward.  
Moving left to right in this plane lets you hit:





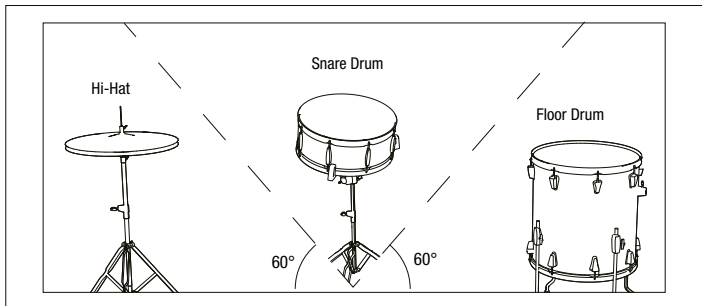
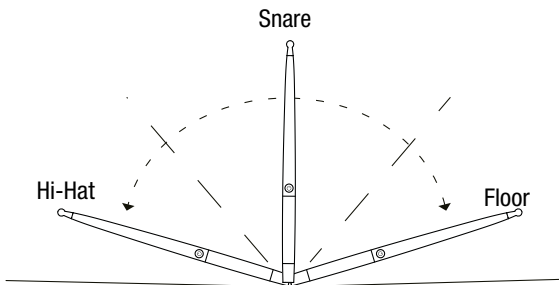

CYMBAL/DRUM	POSITION	SOUND / FUNCTION
 Hi-hat Cymbal	Left	“Tick-tick” – tempo keeper
 Snare Drum	Center	“Clap” – backbeat or accents
 Floor Drum	Right	“Boom” – low rhythmic support

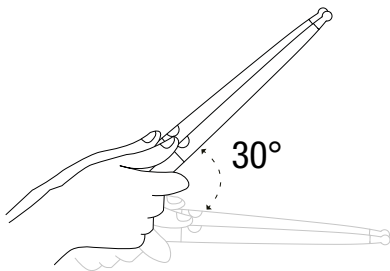

## SECOND PLANE – TILTED PLANE ( $\approx 30^\circ$ UPWARDS)

Tilt your sticks about  $30^\circ$  upwards from the horizontal position. In this plane, moving left to right lets you strike:



CYMBAL/DRUM	POSITION	SOUND / FUNCTION
 Crash Cymbal	Left	"Tsch" – dramatic accents
 Tom Drum 2	Center	"Doom" – fills and rhythmic variation
 Ride Cymbal	Right	"Tsch" – steady rhythmic pattern

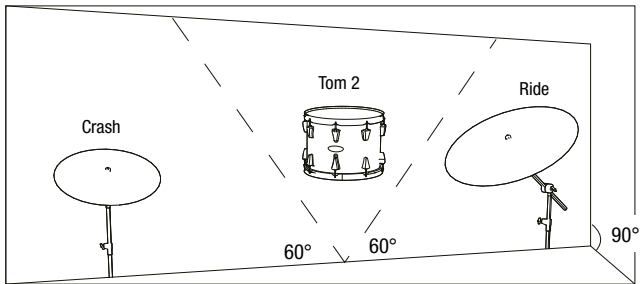



## 2. FOOT-CONTROLLED ELEMENTS – PEDALS

Some drums are not hit with sticks but triggered with foot pedals instead.

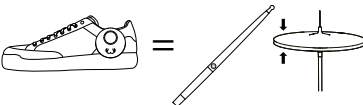
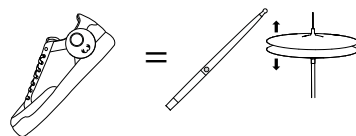
PEDAL	FOOT	FUNCTION
Bass Drum	Right foot	“Boom” – controls the main low-end rhythm.
Hi-hat Pedal	Left foot	“Tick-tick” – tempo keeper. Also opens/closes hi-hat and affects sound of stick hit (open vs. closed hi-hat).
		
		
Pedal Switch	Left foot	Tap 3x to change left pedal between hi-hat and bass drum.

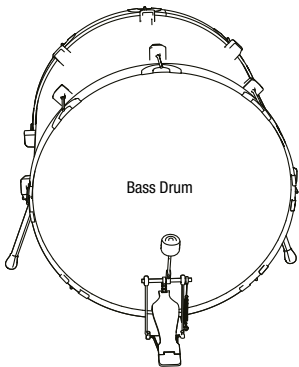
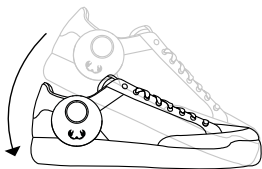
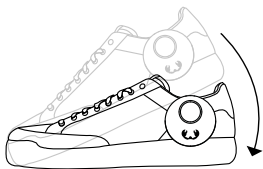

# POSTURE AND TECHNIQUE

1. Sit upright or stand firmly
2. Hold the drumsticks properly
3. Try to learn where each sound comes from
4. Move from your wrists, not your shoulders
5. Tap your foot for the bass drum or hi-hat
6. Breathe calmly and keep your movements smooth

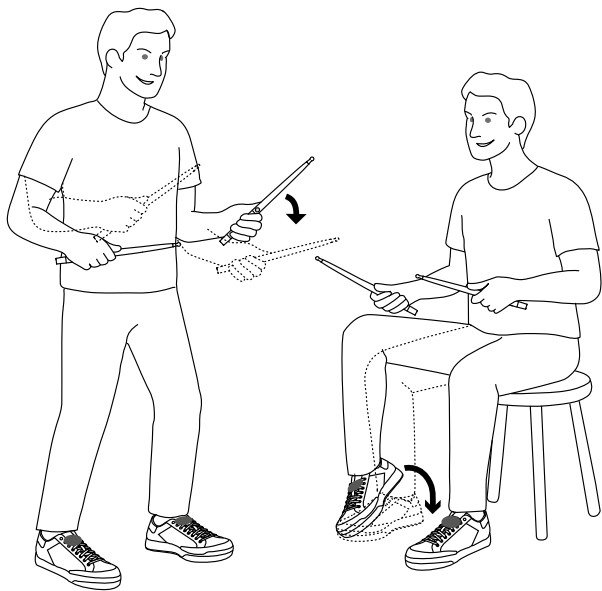

# RHYTHMS + BASIC BEATS + 1 EXERCISE PER LEVEL

x = tap on your hi-hat (right hand)

o = tap on snare (left hand) or kick (right foot)

**TIP** | Count along: “1 and 2 and 3 and 4 and”

## BEAT 1: THE CLASSIC ROCK BEAT

## BEGINNER

### Example track

### “We Will Rock You” – Queen

*This is the most famous beat in the world.  
Ideal for building a sense of rhythm.*

### Notation

(four counts per bar)

Hi-Hat:	x	-	x	-	x	-	x	-
Snare (L):			o					o
Bass drum (R):	o				o			



## BEAT 3: FUNKY SYNCOPATION BEAT

(ADVANCED)

---

### Example track

#### “As It Was” – Harry Styles

*This song features a laid-back beat that plays with pauses. Your snare hits just after the beat, giving it a cool feel. Perfect if you're looking for more of a challenge.*

---

### Notation

Hi-Hat:           x x x x x x x x  
Snare (L):        0                   0 0  
Bass drum (R):  0       0 0

# FREQUENTLY ASKED QUESTIONS (FAQ)

## **What is the charge time, play time, and battery life?**

- Drumsticks: 9 hours play time / 1.5 hours charging
- Foot Pedals: 5 hours play time / 1.5 hours charging
- Speaker: 15 hours play time\* / 2.5 hours charging

\*With volume at 50% and LED ring off

## **Do I need to drum on a surface?**

No – and you shouldn't! Do not hit the drumsticks against any hard surface. This can damage internal sensors and reduce their lifespan. The drumsticks are designed for air drumming only. They track your movements in space, so no drum kit or surface is needed.

Important: Avoid using or calibrating the sticks near sources of magnetic interference (e.g. fridges, loudspeakers, phones, tablets, metallic objects). Keep a distance of at least 1 meter from these, including the Air Drums speaker itself. Just make sure you have some clear space around you and you're ready to play!

## **How does the sound work then?**

The drumsticks send signals wirelessly to the speaker. That's what generates the sound of your drums, which you'll hear your beats through a speaker or headphones.

## **How do I charge the sticks and pedals?**

Via USB-C. One charge gives you hours of playtime. The sticks flash when the battery is low. A USB-A to dual USB-C cable is included.

## **Can I play along with my own music?**

Absolutely! Play your favourite track via Bluetooth on the speaker and drum along with it.

## **Can I use it with headphones?**

Yes, simply plug in your headphones with a 3.5 mm jack into the speaker. Great for silent, focused practice.





**FRESH 'N REBEL**

Keep in touch:



**freshnrebel.com**

**#freshnrebel**

**helpme@freshnrebel.com**



Made in China

